



It's not magic, it's engineering.®

Impact and Airborne Sound Control

GENIEMAT[®] RST

Underlayment for Reduced Sound Transmission



GENIEMAT[®] RST

Sound Control Underlayment

FROM THE INVENTOR OF THE PATENTED TECHNOLOGY (US 6920723, US RE41945, CA 2398262) FOR RECYCLED RUBBER USED FOR IMPACT SOUND INSULATION, DIRECTLY BELOW FLOOR COVERINGS.

GenieMat RST is a flat, resilient, reduced sound transmission mat made from 94% recycled rubber content, used directly under hard surface floor finishes and over concrete and wood construction.

It is used when superior sound control is required in multi-family housing, high-rises, or commercial buildings and protects ceramic tile, porcelain and stone from substrate cracks.

Engineered for direct adhered floor coverings such as tile, stone, wood, and vinyl floor coverings.

Tile – All products rated for minimum of commercial use.

Wood – **GenieMat FAS** adhesives offer superior bonding strength.

Vinyl – One-step method provides superior sound control for resilient floor coverings.

Features and Benefits:

- Mold, bacteria, fungi, and water resistant
- Exceeds pass criteria for point load test for crack isolation membrane (ANSI 118.12)
- Meets requirements for VOC emissions (IAQ test, ASTM D5116)
- Qualifies for LEED[®] points
- Floorscore[®] certified
- Complete floor covering system warranty available

PRODUCT SPECIFICATIONS

PRODUCT	ROLL SIZE	AVERAGE DYNAMIC STIFFNESS (BS EN 29052)	TYPE A HARDNESS (ASTM D2240)	TCNA ROBINSON TEST WITH TILE (ASTM C627)
GenieMat RST02	4' x 75'	157 MN/m ²	50 durometer	Extra heavy commercial
GenieMat RST05	4' x 30'	105 MN/m ²	50 durometer	Moderate commercial
GenieMat RST10	4' x 15'	64 MN/m ²	50 durometer	Light commercial
GenieMat RST12	4' x 12.5'	60 MN/m ²	50 durometer	Light commercial
GenieMat RST15*	2.5' x 4'	54 MN/m ²	50 durometer	Light commercial

* GenieMat RST15 is only available in Sheets

RUBBER IS THE BEST VIBRATION ISOLATION MATERIAL

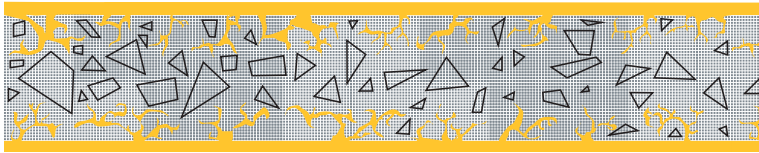

POSITIVE ADHESIVE LOCK
For very high bond strengths with adhered floor coverings

APPROVED FOR PORCELAIN TILE, VINYL SHEET, LUXURY VINYL PLANK, CERAMIC TILE, AND ALL TYPES OF WOOD FLOOR

Fully Warranted Vinyl Plank System

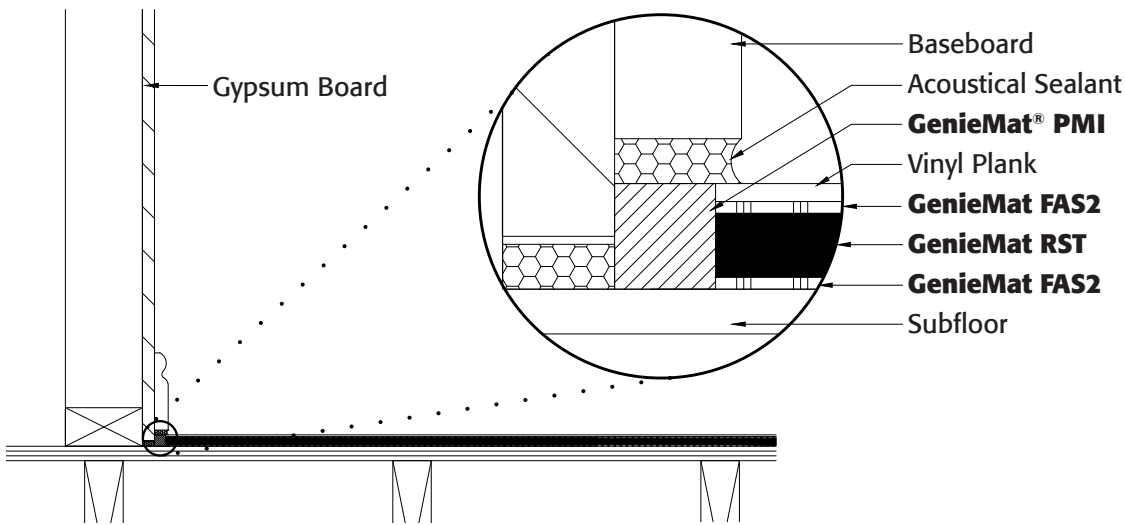

Fully Warranted Ceramic Tile System

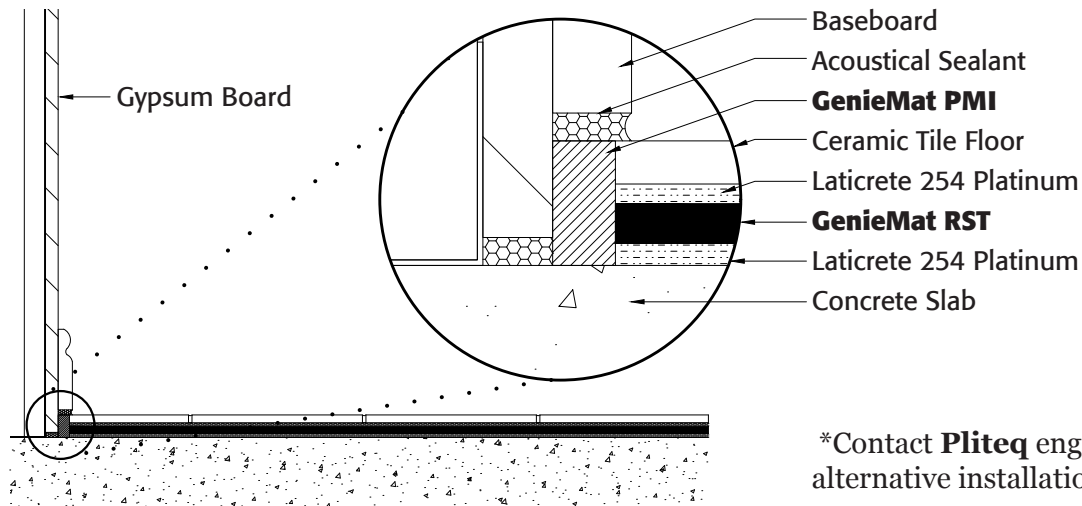

*Contact **Pliteq** engineering for alternative installation methods.

GENIEMAT® RST ACOUSTICAL TEST DATA

IMPACT INSULATION SYSTEM

6" Concrete Slab

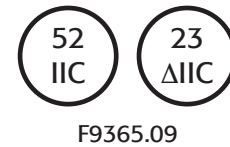
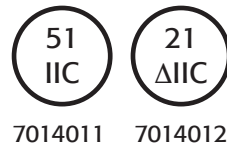
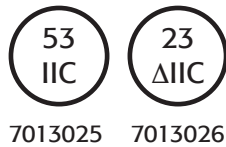
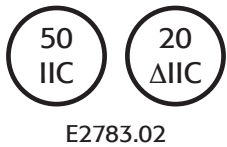
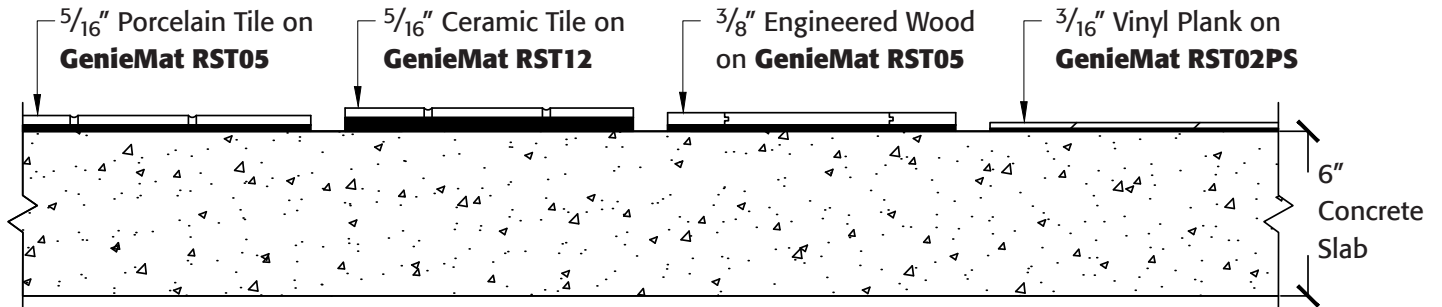

8" Concrete Slab

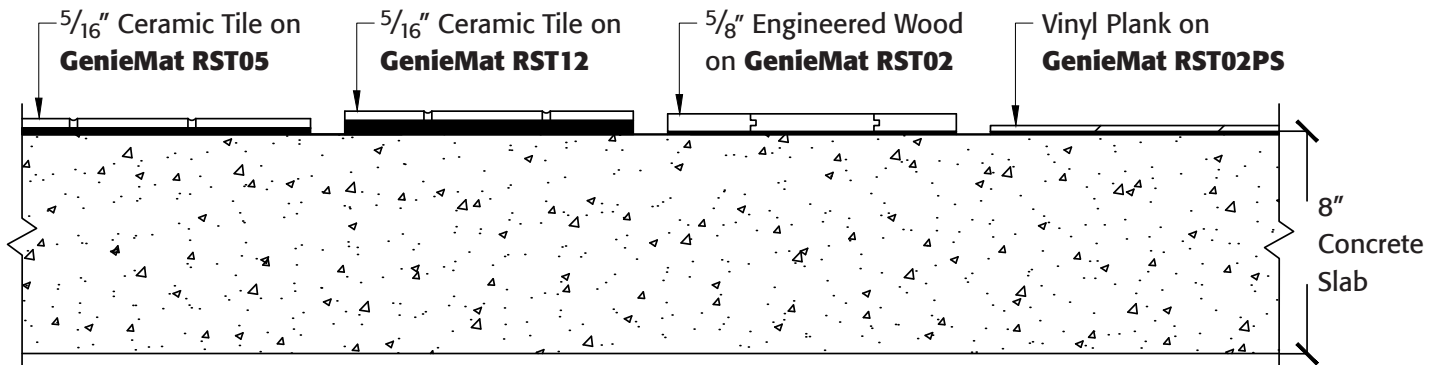

GENIEMAT® RST ACOUSTICAL TEST DATA

IMPACT INSULATION SYSTEM

Hollow Core Plank

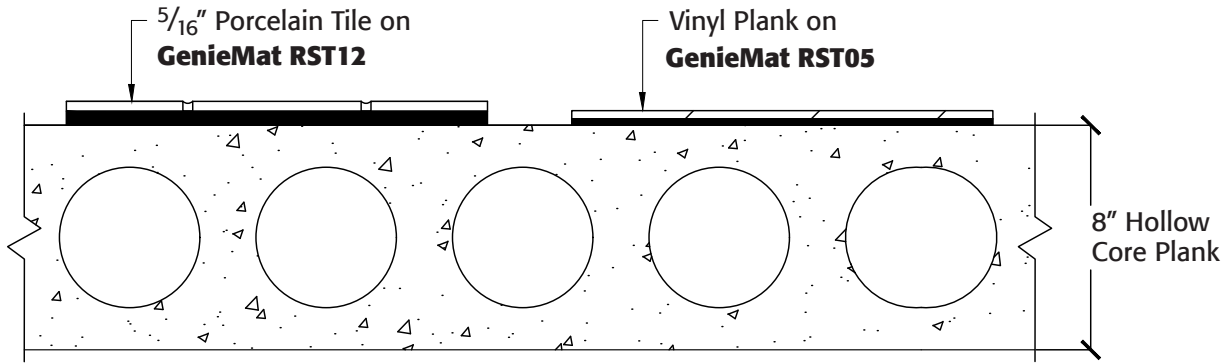

F0223.10



F0223.04

NOTE: No ceiling assembly tested

Composite Deck

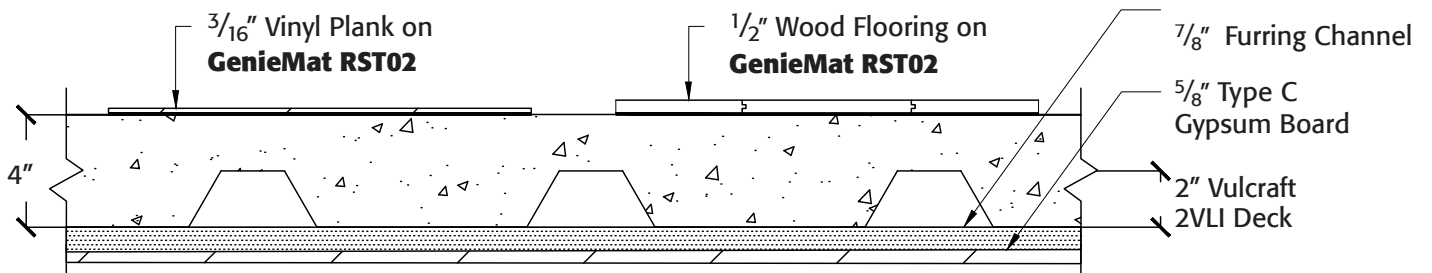

F5689.13



F5689.14

GENIEMAT® RST ACOUSTICAL TEST DATA

IMPACT INSULATION SYSTEM

Open Web Truss

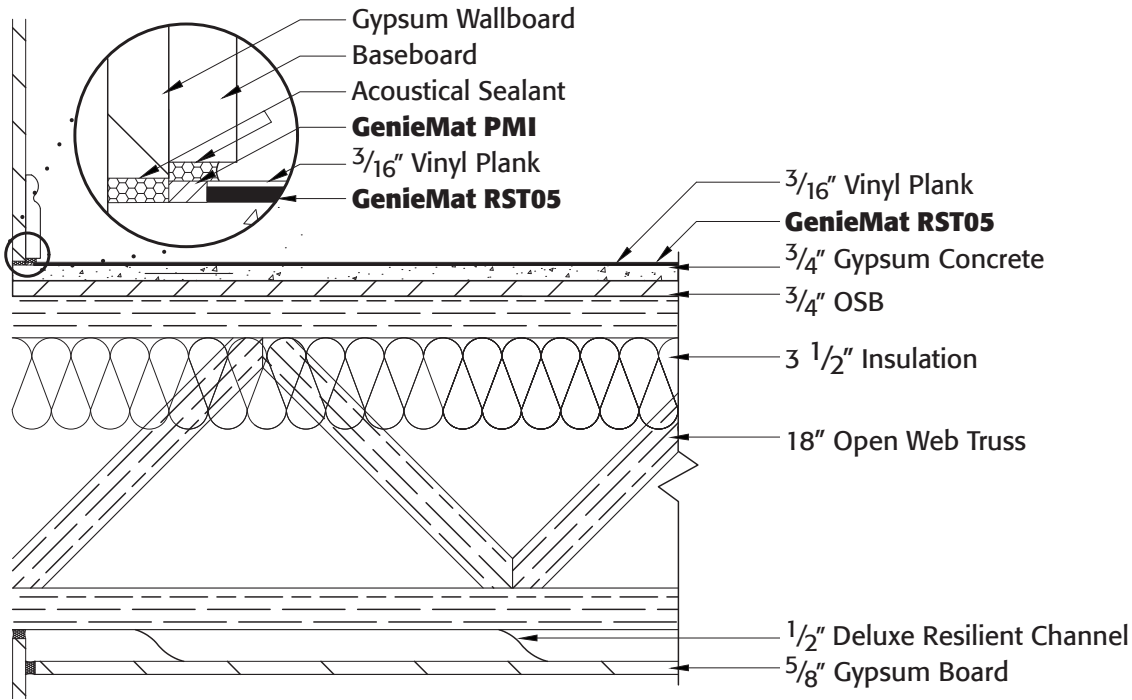

62
STC

56
IIC

E5958.10

UL US

UL Assembly
L521, etc.

Cross Laminated Timber

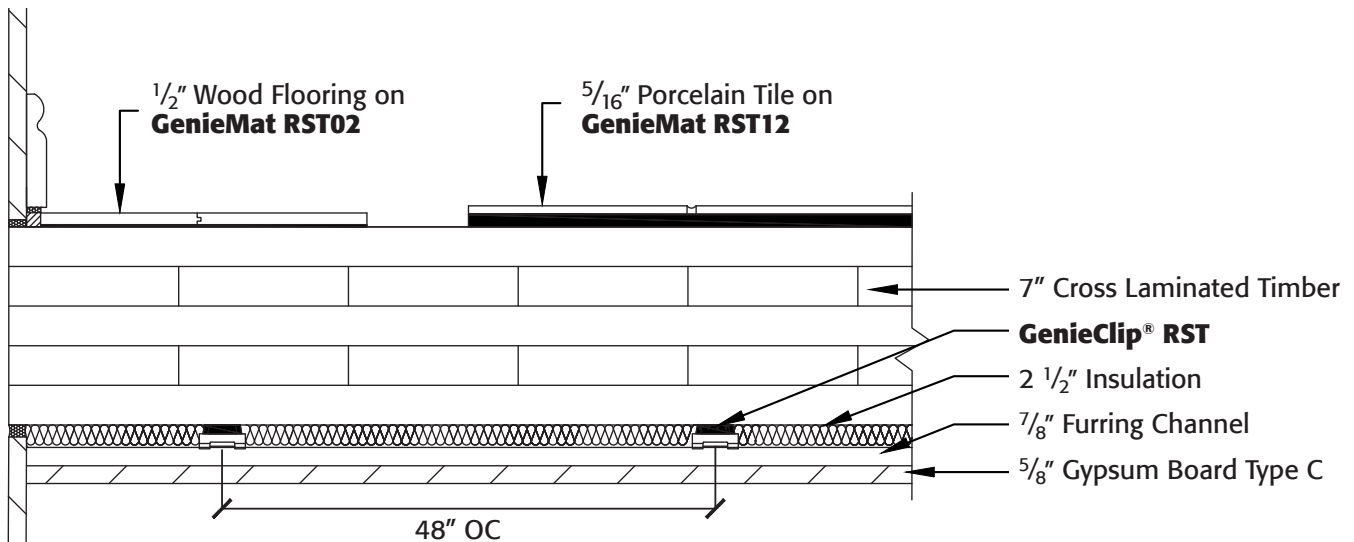

50
IIC

F2761.08

51
IIC

F2761.09

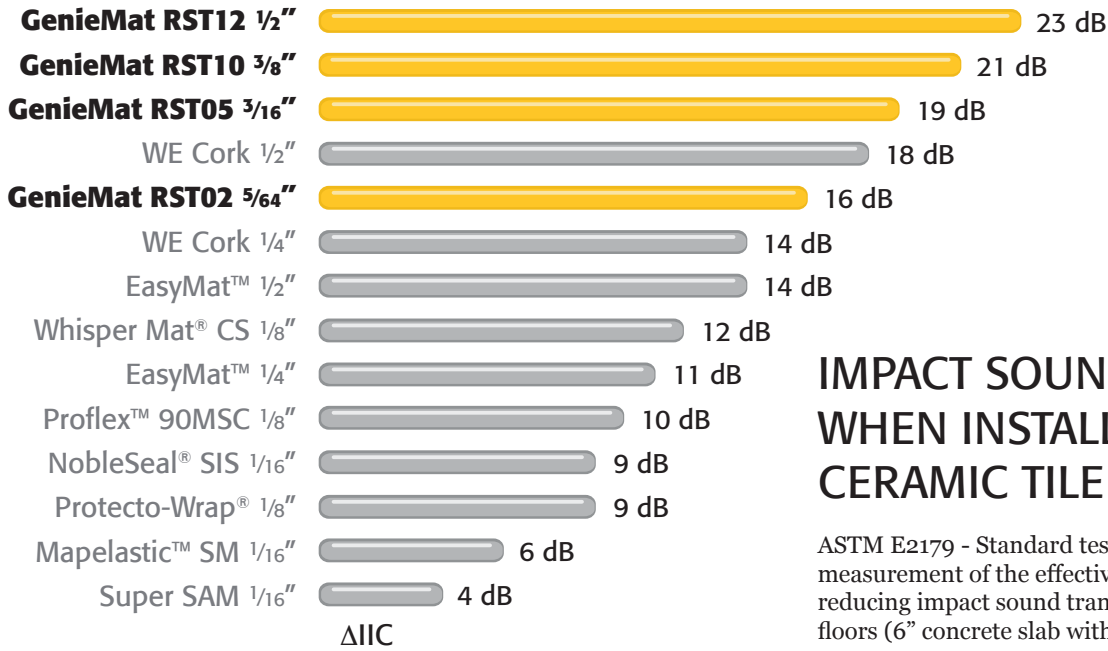

IMPACT SOUND REDUCTION WHEN INSTALLED BENEATH CERAMIC TILE

ASTM E2179 - Standard test method for laboratory measurement of the effectiveness of floor coverings in reducing impact sound transmission through concrete floors (6" concrete slab with tile).

All listed dimensions are nominal.

ACOUSTICAL TESTING STANDARDS - WOOD STRUCTURES							
TEST REPORT NUMBER	PRODUCT	FINISH FLOOR	STRUCTURE	SUBFLOOR	CEILING TYPE	STC RATING (ASTM E90)	IIC RATING (ASTM E492)
G0535.08	GenieMat® RST02PS	Vinyl Plank	Open Web Truss	3/4" Gypsum, 3/4" OSB	1/2" RC Deluxe, 5/8" Type C GWB	60	50
G0535.07	GenieMat RST02PS	Wood	Open Web Truss	3/4" Gypsum, 3/4" OSB	1/2" RC Deluxe, 5/8" Type C GWB	61	50
G0535.01	GenieMat RST02PS	Porcelain Tile	Open Web Truss	3/4" Gypsum, 3/4" OSB	1/2" RC Deluxe, 5/8" Type C GWB	62	51
F4832.18	GenieMat RST02	Porcelain Tile	Engineered Joist	1/2" Plywood, 3/4" OSB	GenieClip RST , 2x 5/8" Type C GWB	59	55
F5500.03	GenieMat RST02	Vinyl Plank	Engineered Joist	1/2" Plywood, 3/4" OSB	GenieClip RST , 2x 5/8" Type C GWB	61	60
F4832.14	GenieMat RST02	Wood	Engineered Joist	1/2" Plywood, 3/4" OSB	GenieClip RST , 2x 5/8" Type C GWB	58	61
F2761.08	GenieMat RST02	Wood	CLT	None	GenieClip RST , 5/8" Type C GWB	54	50
F2761.09	GenieMat RST12	Porcelain Tile	CLT	None	GenieClip RST , 5/8" Type C GWB	55	51
E5958.07	GenieMat RST05	Vinyl Plank	CLT	None	12" Wire Suspended on GenieClip LB , 5/8" Type C GWB	58	58
5013143 7013216	GenieMat RST02	Vinyl Plank	2x10 Solid Wood Joist	5/8" Plywood, 1/2" Plywood	GenieClip RST , 1/2" Type C GWB	55	50
5013136 7013208	GenieMat RST02	Ceramic Tile	2x10 Solid Wood Joist	5/8" Plywood, 1/2" Plywood	GenieClip RST , 1/2" Type C GWB	58	52

TEST RESULTS

ACOUSTICAL TESTING STANDARDS - CONCRETE AND STEEL STRUCTURES							
TEST REPORT NUMBER	PRODUCT	FINISH FLOOR	STRUCTURE	SUBFLOOR	CEILING TYPE	STC RATING (ASTM E90)	IIC RATING (ASTM E492)
G9222.01	None	Vinyl Plank	8" Concrete Slab	None	None	55	43
G9222.04	GenieMat® RST02	Vinyl Plank	8" Concrete Slab	None	None	54	57
E8741.01	GenieMat RST12	Ceramic Tile	8" Concrete Slab	None	None	57	55
F8530.06	GenieMat RST05	Wood	8" Concrete Slab	None	None	55	56
E2783.02	GenieMat RST05	Porcelain Tile	6" Concrete Slab	None	None	54	50
F9365.09	GenieMat RST02PS	Vinyl Plank	6" Concrete Slab	None	None	51	52
G2953.07	GenieMat RST05	Wood	6" Concrete Slab	None	None	52	53
F0223.10	GenieMat RST12	Porcelain Tile	8" Hollow Core Plank	None	None	54	51
F0223.04	GenieMat RST05	Vinyl Plank	8" Hollow Core Plank	None	None	53	52
G3991.07	GenieMat RST05	Porcelain Tile	5 1/2" Trapezoidal Steel Deck	None	GenieClip RST, 5/8" Type C GWB	56	51
G3991.17	GenieMat RST02	Wood	5 1/2" Trapezoidal Steel Deck	None	Furring channel	53	52
F9365.02	GenieMat RST05	Porcelain Tile	4" Trapezoidal Steel Deck	None	GenieClip RST, 2x 5/8" Type C GWB	58	51
F5689.07	GenieMat RST02	Vinyl Plank	4" Trapezoidal Steel Deck	None	GenieClip RST, 5/8" Type C GWB	54	54
F5689.06	GenieMat RST05	Wood	4" Trapezoidal Steel Deck	None	GenieClip RST, 5/8" Type C GWB	55	54
F5689.18	GenieMat RST12	Porcelain Tile	10" Steel Joist	3/4" Structural Concrete Panels	GenieClip RST, 2x 5/8" Type C GWB	62	50
F5689.20	GenieMat RST02	Vinyl Plank	10" Steel Joist	3/4" Structural Concrete Panels	GenieClip RST, 2x 5/8" Type C GWB	60	52
F5689.21	GenieMat RST02	Wood	10" Steel Joist	3/4" Structural Concrete Panels	GenieClip RST, 2x 5/8" Type C GWB	60	53
F3052.15	GenieMat RST10	Porcelain Tile	16" Insulated Concrete Form	None	1/2" Type C GWB	56	51
F3052.14	GenieMat RST05	Wood	16" Insulated Concrete Form	None	1/2" Type C GWB	54	53

GENIEMat RST PRO

Waterproofing and Impact Sound Control System.

GenieMat RST PRO is a waterproofing and impact sound control system designed to provide both moisture protection and acoustic performance in flooring installations. It serves a dual purpose by acting as a barrier against water infiltration while also reducing impact noise transmission, making it an ideal choice for areas where both sound control and waterproofing are essential.

This system is typically used in multi-family housing, hotels, and commercial spaces where sound privacy and moisture resistance are critical. It can be installed under various types of flooring, including tile, hardwood, and laminate, ensuring durability and effective sound insulation.

Features and Benefits

- Waterproof membrane generally applied to the concrete floor to save time, labour and material.
- The highest IIC performance ratings for tile installations.
- Fully waterproof per ANSI 118.10.
- Protect wood flooring from excess moisture vapor in new construction.
- High tensile strength for crack isolation.
- Qualifies for LEED® points.
- Floorscore® certified.
- Complete floor covering system warranty available.
- Mold, bacteria, fungi, and water resistant.

PRODUCT SPECIFICATIONS				
PRODUCT	ROLL SIZE	DYNAMIC STIFFNESS @ 2.5 kPa AND 100 Hz (ASTM D5992)	TYPE A HARDNESS (ASTM D2240)	TCNA ROBINSON TEST WITH TILE (ASTM C627)
GenieMat RST03 PRO	4' x 50'	33 MN/m ³	50 (± 5) Durometer	Extra heavy commercial with tile
GenieMat RST05 PRO	4' x 30'	26 MN/m ³	50 (± 5) Durometer	Moderate commercial with tile
GenieMat RST10 PRO	4' x 15'	20 MN/m ³	50 (± 5) Durometer	Light commercial with tile
GenieMat RST12 PRO	4' x 13'	20 MN/m ³	50 (± 5) Durometer	Light commercial with tile

GENIEMAT RST PRO APPLICATION

Level Drain Detail

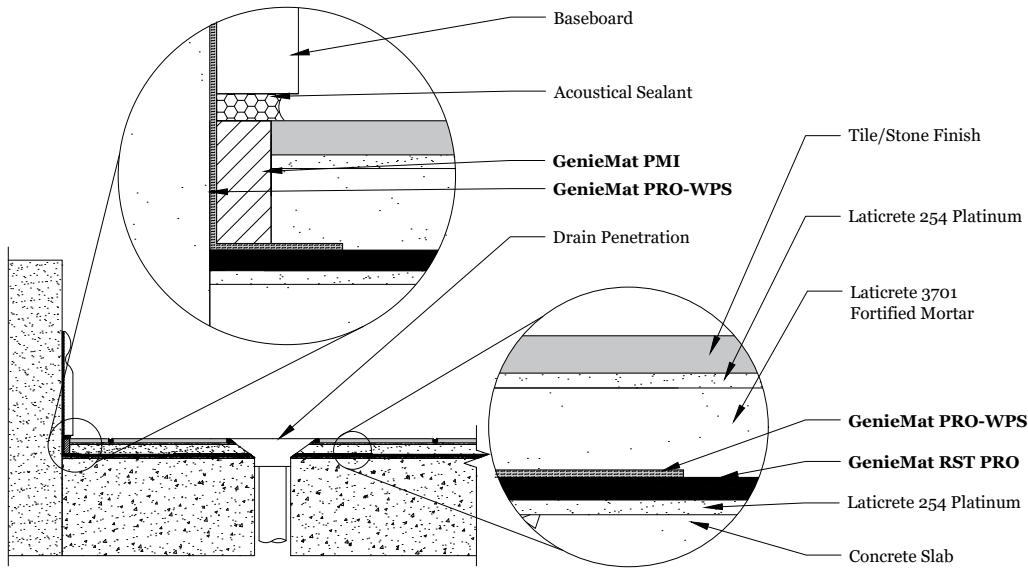

Shower Detail

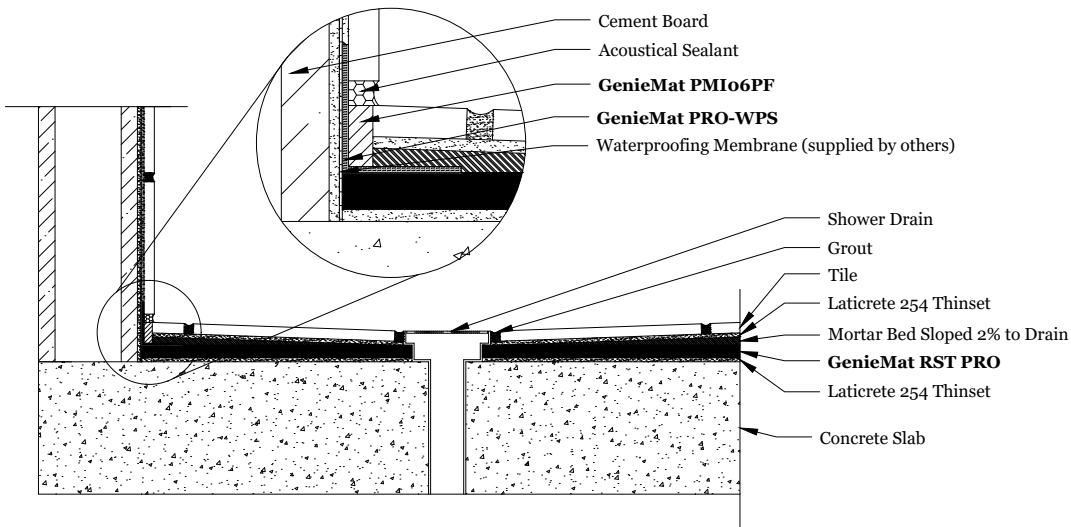

GENIEMAT RST PS

Peel & Stick Sound Control Underlayment

GenieMat RST PS is a flat, resilient, reduced sound transmission mat made from 94% recycled rubber content with a laminated pressure-sensitive adhesive, used directly under hard surface floor finishes and over concrete and wood construction.

Features and Benefits

- Mold, bacteria, fungi, and water resistant
- Exceeds pass criteria for point load test for crack isolation membrane (ANSI 118.12)
- Meets requirements for VOC emissions (IAQ test, ASTM D5116)
- Qualifies for LEED® points
- Complete floor covering system warranty available
- Floorscore® certified.
- Third-party verified EPDs available

PRODUCT SPECIFICATIONS				
PRODUCT	ROLL SIZE	DYNAMIC STIFFNESS (ASTM D5992) (ASTM D4473) (ASTM 4065)	TYPE A HARDNESS (ASTM D2240)	TCNA ROBINSON TEST WITH TILE (ASTM C627)
GenieMat RST02 PS	4' x 40'	7849 N/mm	50 (± 5) Durometer	Extra heavy commercial with tile
GenieMat RST03 PS	4' x 50'	10603 N/mm	50 (± 5) Durometer	Extra heavy commercial with tile
GenieMat RST05 PS	4' x 30'	6956.3 N/mm	50 (± 5) Durometer	Moderate commercial with tile

CONTACT US

For Your Project Specific Questions
T. 416.449.0049 | E. info@pliteq.com

© Pliteq Inc. 2025.

®™ Trademarks of Pliteq Inc. The information provided is accurate to the best of our knowledge at the time of issue. However, we reserve the right to make changes when necessary without further notification. Suggested application may need to be modified to conform with local building codes and conditions. We cannot accept responsibility for products that are not used, or installed, to our specifications. All listed dimensions are nominal.



www.pliteq.com